

SIR ARTHUR LEWIS COMMUNITY COLLEGE
ENGINEERING AND THE CIRCULAR ECONOMY
ACADEMIC YEAR (2024/2025) – SEMESTER ONE

END OF SEMESTER EXAMINATION

TUTOR (S) : Mr. Arnaldo Sanchez-Rojo
PROGRAMME TITLE : Electrical Engineering
COURSE TITLE : Electrical Principles I
COURSE CODE : ELT110
LEVEL : Associate Degree/Year Two
PAPER : One
DATE : Friday, 20th December 2024
COMMENCEMENT TIME : 1:00p.m.
DURATION : 2 Hours
INVIGILATOR(S) : M-L. Felix (Chief), E. Hunte & D. Jn Baptiste
ROOM(S) : CEH-1R-02
STUDENT ID :

GENERAL INFORMATION AND INSTRUCTIONS

- This paper consists of **Three (3)** sections (A, B & C). Students are required to answer **ALL questions**. **Sections A and B must be answered on the question paper.**
- **Section A** consist of twenty (20) multiple choice questions. One (1) mark is awarded for each correct answer.
- **Section B** consist of fill in the blanks. One (1) mark is awarded for each correct answer.
- **Section C** consist of three (3) questions. **Fifteen Marks (15)** are awarded for each question. Answer this section on the **foolscap provided**.
- **Calculators are needed.**
- Students must sign **IN** and **OUT** on the examination class list.
- Students must **not** write their names on their answer sheets, only their ID number
- Please number your responses accordingly.
- **Note: Bags, Books as well as writing paper not given by the invigilator should be deposited at the front of the examination room or as otherwise indicated.**
- **All cell phones must be turned off during the exam.**

**DO NOT TURN THIS COVER SHEET UNTIL
YOU ARE TOLD TO DO SO!!!**

SECTION A - Multiple Choice Questions.

Answer **all** questions. **(One mark is awarded for each correct answer.)**

1. The following figure shows the structure of an atom; which part of the atom is being pointed out?

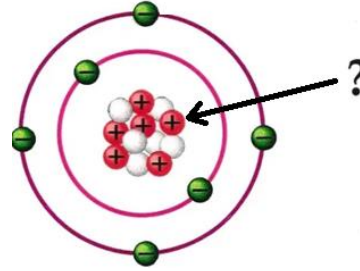

- (A) Protons
 (B) Electrons
 (C) Neutron
 (D) Nucleolus
2. An atom becomes an ion when:
 (A) It gains one or more electrons.
 (B) It loses one or more electrons.
 (C) It gains or loses one or more electrons.
 (D) None of the above
3. Which of the following is the formula of ohms' law?
 (A) $V=I / R$
 (B) $I=V / R$
 (C) $R=V + I$
 (D) All the above
4. In ohm's law _____ is directly proportional to resistance?
 (A) Voltage
 (B) Current
 (C) Inductance
 (D) All the above
5. A potential difference of 110 V is applied across a conductor whose resistance is 25 ohms. What is the value of current flowing through it?
 (A) 0.23 A
 (B) 4.40 A
 (C) 220 A
 (D) 11.0 kA
6. An electrical bulb draws 0.92 A current when connected to a 230 V wall outlet, the resistance of bulb is:
 (A) 20.8Ω
 (B) 229.08Ω
 (C) 211.6Ω
 (D) 250Ω

7. What is the voltage source for a circuit carrying 2 A of current through a 9 Ω resistor?
 (A) 1.8 V
 (B) 18 V
 (C) 7 V
 (D) 4.5 V

8. An appliance is rated at 5 kW, 240 volts. What's the current drawn from the supply?
 (A) 20.833 A
 (B) 0.0208 A
 (C) 20.833 mA
 (D) 48 A

9. The following symbol represents:

- (A) A magnet
 (B) A capacitor
 (C) An Inductor
 (D) A resistance

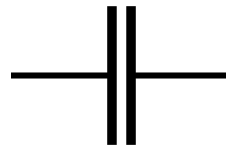

10. What letter we use to represent “Conductance”?

- (A) I
 (B) R
 (C) C
 (D) G

11. Conductance can be calculated:

- (A) 1/V
 (B) 1/R
 (C) V/C
 (D) I*R

12. What is the voltage across R2?

- (A) 6.67 V
 (B) 15 V
 (C) 33.3 V
 (D) 50 V

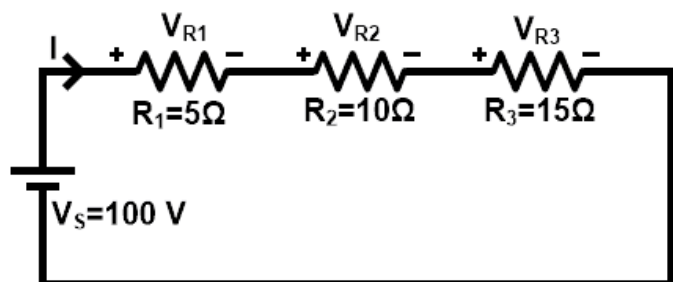

13. Find current “ I_1 ”.

- (A) 0.024 A
- (B) 1.20 A
- (C) 4.80 A
- (D) 5.976 A

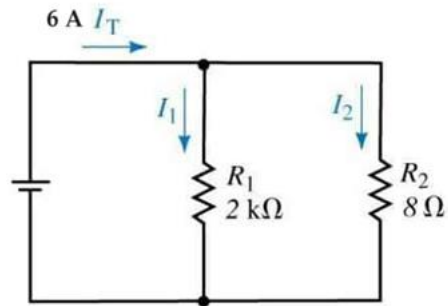

14. Using the Resistor Color Code. Chose the resistance and tolerance of this resistor

- (A) $1\text{ k}\Omega \pm 10\%$
- (B) $1000\ \Omega \pm 2\%$
- (C) $0.1\text{ k}\Omega \pm 5\%$
- (D) $100\text{ k}\Omega \pm 5\%$

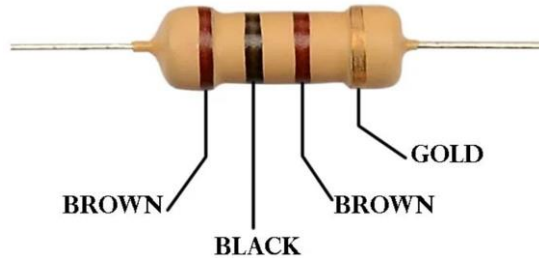

15. Which of these is NOT a method to make a magnet

- (A) Using electric current
- (B) Passing electric current through the magnet
- (C) Single touch method
- (D) Double touch method

16. The magnetic property of the magnet can be destroyed

- (A) Hammering the magnet repeatedly.
- (B) Heating magnet to very high temperature.
- (C) Leaving the poles of the magnet bare for long time.
- (D) All the above

17. Inductors can be classified according to the material used in their core. Which of the following is NOT one of these classifications?

- (A) Iron Core Inductor
- (B) Air Core Inductor
- (C) Plastic Core Inductor
- (D) Ferrite Core Inductor

18. Fleming’s right hand rule is mainly applicable

- (A) to electric motors
- (B) to generators
- (C) to find the cardinal points (north, south, east and west)
- (D) to speak by sign language

19. The figure represents the Fleming’s left hand rule. What vector indicates the index finger?
- (A) Direction of force experienced by the wire.
 (B) Direction of the current in the wire.
 (C) Direction of the magnetic field.
 (D) Direction of the voltage.

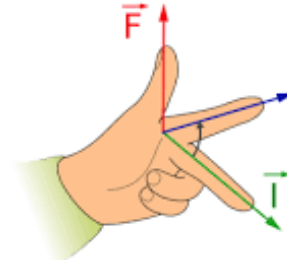

20. The difference between a primary cell and a secondary cell is:
- (A) primary cell can only be used in vehicles.
 (B) primary cell is discarded when its electrical energy is exhausted but a secondary cell can be recharged.
 (C) primary cell has bigger capacity than secondary cell.
 (D) primary cell can be recharged and secondary cell do not.

[TOTAL 20 MARKS]

SECTION B - Fill in the Blanks.

Choose the most appropriate answer from the list below. Answer **all** questions.

Voltage	Electric Current	Conductor
DC Current	Conductance	Reluctance
Capacitor	Resistance	Cell
	Fleming Left-Hand Rule	

- _____ of the magnetic circuit is the ratio of the magneto-motive force to the flux.
- _____ it is a measure of the opposition to current flow in an electrical circuit.
- _____ it is a type of electrical current, in which flow constantly in one direction.
- _____ denotes how easily electricity can pass through an electrical component for a given voltage difference.
- _____ is defined as the electrical potential per unit charge between two points in an electrical circuit r electric field.
- _____ is a material or substance that allow the flow of current through it.
- _____ is the ordered flow of electrons.
- _____ is a component which has the ability or capacity to store energy in form of electrical charge producing a potential difference across it plates.
- _____ is mainly applicable to electric motors to find direction of rotation.
- _____ is a device that stores chemical energy and makes it available in an electrical form. In this device chemical energy is directly converted to electrical energy.

[TOTAL 10 MARKS]

SECTION C - Long Answer Questions

Answer **all** questions on the foolscap provided.

Question One

Find the equivalent resistance between A and B.

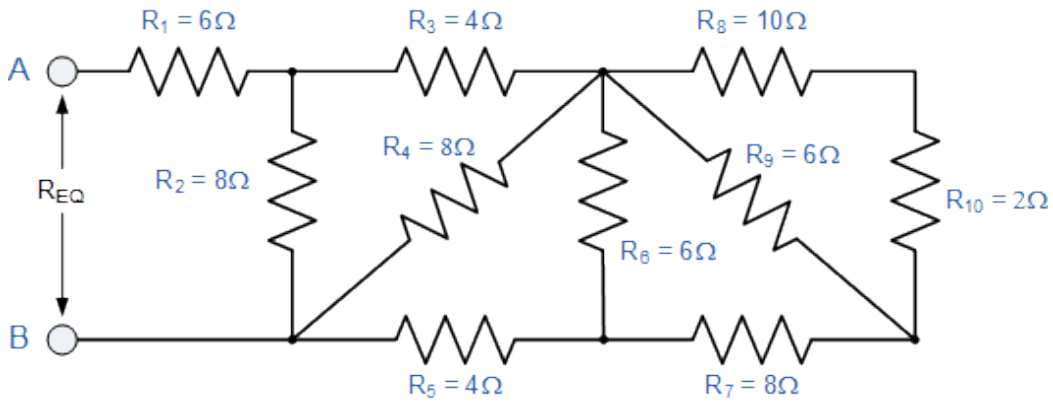

(15 Marks)

Question Two

Two square metal plates, each of size 200 mm, are completely immersed in insulating oil of relative permeability 5 and spaced 3 mm apart. A p.d. of 600 V is maintained between the plates.

Calculate:

- (A) The capacitance of the capacitor
- (B) The charge stored on the plates
- (C) The electric field strength in the dielectric
- (D) The electric flux density.

Note: permeability of free space is: 8.85×10^{-12} F/m

(15 Marks)

Question Three

A coil of 600 turns is wound uniformly over a wooden ring having a mean circumference of 200 mm and a uniform cross-sectional area of 500 mm^2 . If the current through the coil is 5 A.

Calculate:

- (A) The magnetic field strength
- (B) The flux density
- (C) The total flux

Note: $\mu_0 = 4\pi \times 10^{-7}$ Hm

(15 Marks)

[45 MARKS TOTAL]